

INSTALLATION & OPERATION GUIDE

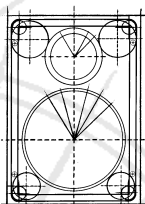

blueprint
series
IN-WALL
LOUDSPEAKERS®

M O D E L
PSW800
SUBWOOFER

orint
ies

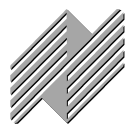

NILES®

BLENDING HIGH FIDELITY AND ARCHITECTURE®

W A L L
E A K E R S

Congratulations!

Thank you for choosing a Niles loudspeaker. With proper installation and operation, you'll enjoy years of trouble-free use.

The PSW800 wall mount subwoofer is uniquely designed to provide unobtrusive low frequency augmentation. The selectable high and low-pass filters make it suitable for use with a wide variety of satellite speakers.

Niles manufactures the industry's most complete line of custom installation components and accessories for audio/video systems. For a free full line catalog write: Niles, Catalog Request, P.O. Box 160818, Miami, Florida 33116-0818

TABLE OF CONTENTS

FEATURES AND BENEFITS	2
HOW MANY SUBWOOFERS?	4
CONNECTIONS	5
IMPEDANCE	7
TREATMENT & PLACEMENT	9
INSTALLATION FUNDAMENTALS	10
INSTALLATION IN NEW CONSTRUCTION	14
INSTALLATION IN EXISTING CONSTRUCTION	15
FINAL INSTALLATION IN NEW OR EXISTING CONSTRUCTION	16
OPERATION	18
SPECIFICATIONS	19
WARRANTY REGISTRATION CARD	21
LIMITED WARRANTY	22

Features and Benefits

Mica-Filled, Dual Voice Coil Polypropylene Woofer

The mica-filled polypropylene woofer utilized in the PSW800 is optimized for transient speed and dynamics. The mica filling adds just the right amount of stiffness while

at the same time reducing the overall cone weight. This combination offers phenomenal rigidity and stiffness-to-mass characteristics that make it especially suited for low frequency reproduction. Niles speaker engineers have coupled this exceptional cone material with a dual voice-coil drive system that enables installers to custom configure single or double woofer systems to a stereo amplifier.

Figure 1
Model PSW800 Shown

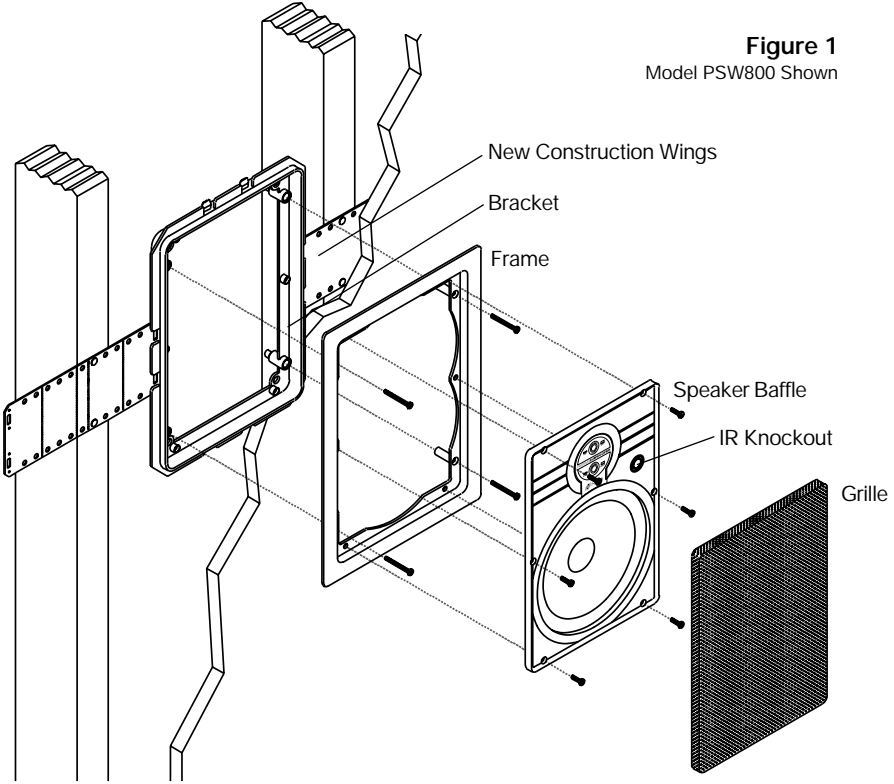
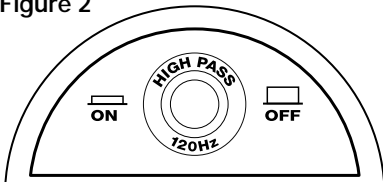
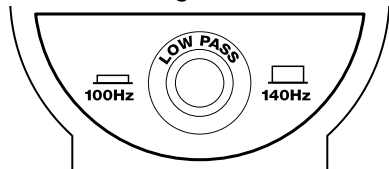

Figure 2



The PSW800 In-wall subwoofer includes an easy access, baffle mounted high-pass filter to prevent over-excursion of the satellite's woofers.

Figure 3



The PSW800 In-wall subwoofer includes an easy access, baffle mounted low-pass frequency selection switch.

Inverted Dust Cap

The inverted dust cap feature of the PSW800 actually reinforces the cone to further increase the stiffness-to-mass ratio and reduce distortion. In a subwoofer application, this dust cap inversion offers the additional benefit of reducing the “oil can” effect that can cause traditional woofers to produce unwanted high frequency overtones.

High Power Handling

The PSW800 employs an exceptionally heavy-duty magnet/voice-coil/spider assembly that is capable of handling high power amplifiers (up to 150 watts).

Infinite Baffle Design

The PSW800 is designed for optimum low frequency reproduction in a traditional 2 x 4 stud wall with varying air volumes. It does not require a special enclosure to provide high performance.

Selectable Low-Pass Filter

Installers can select to roll off the high frequencies from the PSW800 at 12dB per octave at either 100Hz or 140Hz. This selection is accomplished via baffle-mounted controls that are accessible even after the subwoofer has been installed.

Selectable High-Pass Filter

Installers can also select whether or not to filter the low frequencies from the satellite speakers at a fixed frequency of 120Hz. Like the low-pass filter, this selection is accessed via baffle mounted controls.

Weatherproof Construction

All components of the PSW800 are weatherproof. The aluminum grille and stainless steel mounting screws are rustproof. This makes the subwoofer ideal for moist environments which would cause some brands of speakers to discolor. Protected outdoor installations are perfectly suited for the PSW800.

MicroPerf™ Grilles

The PSW800 employs Niles' exclusive MicroPerf grille construction. The exceptionally tight hole pattern provides acoustic transparency at all audio frequencies and enables the woofer element to remain invisible. MicroPerf grilles can be painted to blend seamlessly with the surrounding decor.

14 AWG Input/Output Terminals

The PSW800 is equipped with both left and right speaker level input terminals to accommodate a stereo amplifier driving a single subwoofer. Output terminals are also provided to utilize the switchable low-pass filter and provide for convenient wiring to the satellite speakers.

Easy Retrofit Installation in your Existing Home

Designed for ease of installation, the Niles mounting system makes retrofit installations simple and fast. A supplied template assures fast and accurate hole cutting. The bracket slips behind the drywall and the screws secure the bracket to the frame, sandwiching the drywall between them. The speaker baffle attaches to the frame, and the grille mounts over the speaker.

Three Stage Installation System for Remodels or New Construction

You install only the parts you need for a particular stage of construction. When the framing and wiring are finished, you install the *bracket*. After the drywall is up, but before the painter begins to paint, you install the *frame* and provide the rustproof aluminum *grilles* to the painter so that they can be painted to match the surroundings. Only when construction is completely finished do you put the valuable *speaker* in the wall. You don't have to mask or prep the speaker for painting, and worries about theft during the final phases of construction are never an issue!

How Many Subwoofers?

For most applications a single PSW800's is appropriate. However, in large rooms, high performance listening rooms or in home theaters, an array of two or more PSW800 will deliver astounding results. Unlike other subwoofer systems, a Niles Subwoofer Array is concealed. Consider the distance between the subwoofer(s) and the listener, the size of the amplifier, and the desired quality and volume of sound when deciding how many PSW800s to install in your home.

Decibels and Power

65dB	Conversation at three feet.
75dB	Sewing Machine at three feet.
85dB	Vacuum Cleaner at 10 feet.
95dB	Subway Train entering a station at 20 feet.
3dB	The smallest difference in volume the human ear can easily detect.
10dB	Perceived as twice as much loudness if it is an increase (half as much if it is a decrease).

Any speaker requires twice as much amplifier power to increase 3dB and ten times as much power to increase 10dB.

Comparison of 1, 2 or 4 Subwoofers 16' x 18' x 8' Room @ 12'

	25 Watts	100 Watts
1 Sub	95dB	101dB
2 Subs	100dB	106dB
VLSA of 4 Subs	103dB	109dB

2 x Watts = 3dB Increase in Volume.
 2 x Subs = 3dB Increase in Volume.
 2 x Subs = 1/2 the subwoofer excursion for the same volume.

If you double the distance from the subwoofer to the primary listening position you decrease the volume by 4 to 6dB.

Single Stereo Subwoofer

One PSW800 can produce the bass sound from both the left and the right channels because of its unique dual voice coil design. One voice coil powers the left channel and the other powers the right channel. A stereo crossover divides the signal and filters it according to the settings of the switches on the front panel. A single stereo subwoofer is compatible with any 4 ohm stable amplifier. Eight ohm stable amplifiers may be used with a Niles IM volume control (see Impedance section on Page 7)

Dual Subwoofer Systems

Using two PSW800 subwoofers in a system raises the maximum attainable volume of the system by 3dB. Additionally, at lower volumes, excursion — and therefore distortion levels — are reduced. In a large room, or a home theater system, the effect on bass quality is extremely desirable. Another 2dB increase is possible if the voice coils of each are PSW800 paralleled. This requires a multi-channel amplifier or an amplifier capable of driving the 2 to 2.6 ohm load of the overall system.

VLSA Installations

A Very Large Subwoofer Array (VLSA) installation lowers the amount of excursion required to achieve a high sound pressure level. Lowering excursion dramatically improves the quality of the sound. VLSA installations are most appropriate when the listener appreciates detail and bass extension, but must have a concealed installation. A VLSA of four subwoofers must have a multi-channel amplifier with one channel assigned to each subwoofer. (See Figure 7).

Connections

Single Stereo Subwoofer

A four conductor wire (Left+, Left-, Right+ and Right-) 16 gauge or larger is run from the amplifier location to the local volume control. (See Figure 4).

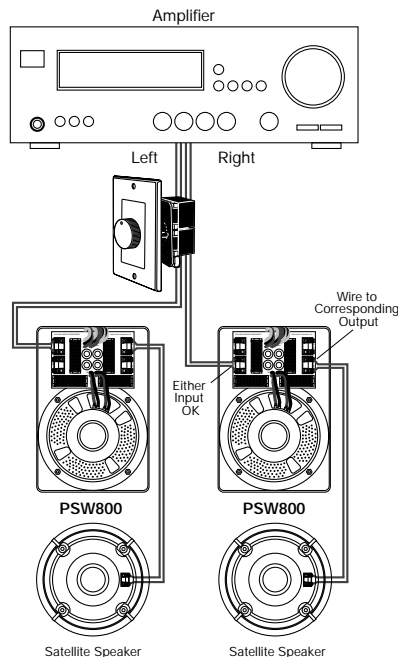

Figure 4
A Single PSW800 Hook-Up

From the local volume control, the four conductor wire is run to the PSW800 and connected to the Input connectors. A two conductor wire is connected to each of the stereo outputs and fed to the left and right speakers. Now, the volume control will raise and lower the volume for the subwoofer and the left and right speakers simultaneously. Additionally, the crossover is now connected so that the crossover switches can be adjusted.

Dual Subwoofer Systems

A four conductor wire (Left+, Left-, Right+ and Right-) 16 gauge or larger is run from the amplifier location to the local volume control. (See Figure 5).

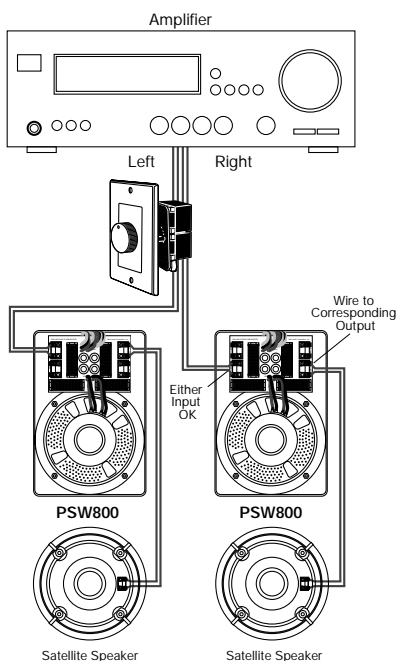

Figure 5
A Dual PSW800 Hook-Up

From the local volume control, a two conductor cable is run to each of the PSW800s and connected to either the left or the right Input connectors.

Each of the satellite speakers must be connected to the correct subwoofer. Typically, a two conductor wire is connected from the left channel output on the left channel subwoofer and fed to the left satellite speaker and another two conductor wire connects from the right channel subwoofer output to the right channel satellite.

Now, the volume control will raise and lower the volume for the subwoofer and the left and right speakers simultaneously. Additionally, the crossovers are now connected so that the crossover switches can be adjusted to your requirements. You must adjust the crossovers on each subwoofer with this hook-up.

Optionally, a jumper of wire may be connected between the L+ and the R+; and between the L- and the R-. This connects both voice coils of the PSW800, giving you a 2dB increase in output. Since each subwoofer's impedance drops from 8Ω to 4Ω, make sure your amplifier is 2Ω stable to accommodate the satellite speaker's impedance. (See Figure 6).

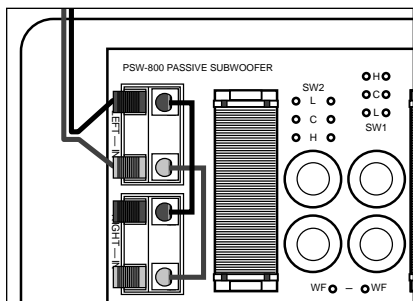

Figure 6
Connecting the two voice coils in parallel with a jumper (a piece of speaker wire).

Very Large Subwoofer Array (VLSA)

Using four or more PSW800 subwoofers in a system creates a system of unprecedented clarity, with stunning bass impact and potentially extraordinary maximum volume capability. Because of the extremely low impedance of a parallel VLSA system, multiple channel amplifiers are normally used to power them. Because of this, in-wall volume controls are incompatible with VLSA systems.

In a system of this type, it is recommended that the satellite speakers be driven full

range (or with an external electronic crossover) by a separate amplifier channel. Connections are straight-forward; two conductor wires connect each amplifier channel to each individual subwoofer. (See Figure 7).

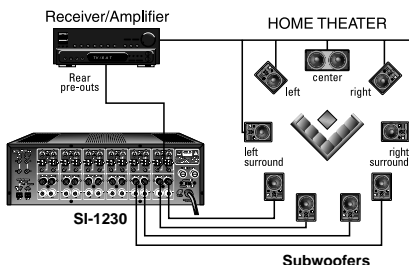

Figure 7
Connections to a VLSA are normally made from each PSW800 to a multi-channel amplifier like the Niles SI-1230 twelve-channel amplifier.

Each PSW800 has a jumper installed to parallel the voice coils for maximum efficiency. (See Figure 6).

The crossover controls on each subwoofer affect only the subwoofer response. Level controls on the amplifiers facilitate blending and compensation for placement.

Speaker Wire

For most applications, we recommend you use 16 or 18 gauge wire. For wiring runs longer than 80 feet we recommend 14 gauge wire. The spring loaded terminals of the PSW800 speakers will accommodate up to 12 gauge wire directly. Larger sizes can be accommodated via pin connectors. When you run wire inside walls, special jacketing (CL-2 or CL-3) is required to both protect the wire and for fire prevention. In some areas conduit is required. For a trouble-free installation, low voltage wire such as speaker wire must be run in accordance with the National Electrical Code and any applicable provisions of the local building code. Consult your local Niles dealer or your building contractor if you are unsure of code requirements in your area.

Impedance

With One or Two Subwoofers

When one or two PSW800 subwoofers are connected to the satellite speakers, the overall system impedance to the amplifier lowers.

System Impedance in Ohms (Ω) One or Two Subwoofers		
	8 Ω Sats	4 Ω Sats
1 Sub	4 Ω	2.6 Ω
2 Subs @8 Ω each	4 Ω	2.6 Ω
2 Subs @4 Ω each	2.6 Ω	2 Ω

If the impedance is too low for your amplifier, utilize a Niles speaker selector or IM volume control to match the impedance.

VLSA (Four or More Subwoofers)

A VLSA installation lowers the amount of excursion required to achieve a high sound pressure level. Lowering excursion dramatically improves the quality of the sound. VLSA installations are most appropriate when the listener appreciates detail and bass extension, but must have a concealed installation.

Each subwoofer should have its voice coils connected in parallel for full output, therefore **the impedance of each is four ohms**. Because of this low impedance, a multi-channel amplifier stable to four ohms is the best way to drive more than two subwoofers. Each PSW800 is connected to its own channel of the multi-channel amplifier.

Check Your Amplifier's Specs

Every amplifier has a minimum impedance specification. Check your owner's manual for the specification for four ohm low impedance drive capability. If there is no

clear indication and your amplifier or receiver has two sets of speaker terminals (typically labeled "A" and "B") your amplifier may be capable of driving a four ohm load. Perform the following test to be sure:

Parallel/Serial Speaker Connection Test

1. Hook up one pair of speakers to the "A" speaker terminals of your amplifier. Leave the "B" terminals unconnected to speakers.
2. Engage both the "A" and the "B". Listen for sound.

If your amplifier plays sound when "A" and "B" are engaged, it is capable of driving a four ohm speaker load. If your amplifier does not play sound when "A" and "B" are selected, it is only capable of driving an eight ohm speaker load. An eight ohm stable amplifier may only be used with a PSW800 satellite/subwoofer system by installing an impedance magnifying volume control.

An amplifier stable to four ohms may be connected without impedance matching devices. Parallel connections via the "A" speaker terminals to one or two PSW800 subwoofers (If the voice coils are not in parallel) and one pair of eight ohm satellite speakers results in a four ohm load.

The "B" speaker terminals cannot be used to power a second pair of speakers anymore. The low impedance drive capability of your amplifier is already utilized by the satellite/subwoofer combination. If you are connecting other speakers in other rooms you must install either a speaker selector or impedance magnifying volume controls.

A few professional/audiophile amplifiers advertise the capability of driving two ohm speaker loads. These amplifiers may be used without impedance matching devices if the rating is quoted as "RMS" or "Continuous" power.

Using Speaker Selectors With Standard Volume Controls

In multi-room systems with standard volume controls any Niles speaker selector will maintain a four ohm load if you leave one set of room outputs unused for every speaker system with an impedance of less than four ohms (such as a PSW800 connected to a pair of four ohm satellite speakers). The protection switch must be constantly engaged. Niles HDL series speaker selectors have a rear panel constant protection feature. (See Figure 8).

The benefit of a speaker selector is that even with the protection circuit constantly engaged, more power will be delivered to any single pair of speakers playing by itself (all other speakers off).

In a multi-room system there is one indispensable control for true convenience—a local volume control. It allows you to adjust the volume of the speakers and the subwoofer without leaving the room.

Niles makes a wide range of high performance indoor and outdoor volume controls in Standard or Decora® style face plates (just like your light switches and dimmers). All of these volume controls enable full power to be delivered to each speaker system when turned all the way up.

The combination of a speaker selector and a standard volume control will deliver high volume when only one pair of speakers is playing.

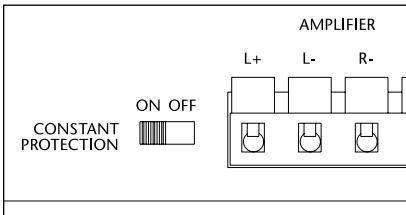
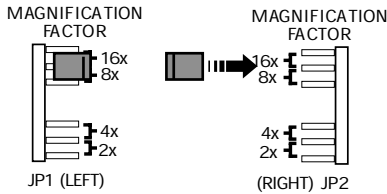

Figure 8
Setting the constant protection switch on the **Rear Panel** of a Niles HDL series speaker selection system.

Using Impedance Magnifying Volume Controls

The simplest way to increase the impedance of a satellite/subwoofer system is to install a Niles VCS-2D-IM or VCS-2S-IM impedance magnifying volume control instead of a standard volume control. This control has a behind the wall jumper which is set at the time of installation to “magnify” the speaker system’s impedance.

(See Figure 9).



For example: In the two times position, an IM volume control will enable an eight ohm stable amplifier to play a 4 ohm speaker system without overheating. The available power will decrease, which you will perceive as a 3dB drop in maximum undistorted volume.

If the jumper is set to the 4x position, a 6dB drop in volume will be perceived.

If the jumper is set to the 8x position, a 9dB drop in volume will be perceived.

A 10dB drop is perceived as half as loud, so there are limits to the amount of magnification you can use unless the amplifier is very powerful (3dB increase every time you double the power) or you never listen at high volumes. Consult the Decibels and Power chart on page 4.

Treatment & Placement

Typically, sheetrock encloses the subwoofer in most installations. Sheetrock has a fairly loud resonant “twang” compared to the rigid non-resonant enclosures of most floor standing subwoofers. None of the following modifications are absolutely necessary, however any one or combination of them will improve the performance of the subwoofer.

Minimum Enclosure Size

The PSW800 will produce magnificent results if the wall cavity behind the woofer is a minimum of 1900 cubic inches. If the wall studs center measure 4” deep (2x4) and are spaced 14-1/4” apart (16” spacing) you would want the length of the air cavity to be a minimum of 33-1/3”. A larger cavity is fine.

Insulation

Lay a batten of fiberglass insulation (e.g. R-19 un-batted insulation) behind of the speaker. If you have more than one subwoofer in the room, place the same amount of insulation behind each subwoofer. If your enclosure is smaller than the recommended 1900 cubic inches, try packing more insulation into the space behind the speaker. This effectively increases the enclosure size.

Enclosure Bracing

Insert small pieces of 1x2 or 1x1 scrap wood as wedges between the front and back panels of sheetrock if possible. Do not use too long of a piece as you could create a bulge in the wall surface.

Enclosure Lining

Purchase some subwoofer damping material from a car stereo store (there are various brands available, e.g. Dynamat™). Apply the damping material to the back of the wall behind the PSW800 and to the sheetrock surrounding the wall beside the subwoofer.

Speaker Placement Techniques

Although the PSW800 has extensive ability to compensate for unusual placements with its crossover switches; placement is still the primary tool for satisfying your particular listening needs.

Maximizing Output

The Boundary Effect – Placing your subwoofer near the floor or in a corner will increase the volume of bass sound produced by the subwoofer! This is called the boundary effect. Generally, you can expect a 3dB increase in sound pressure level by harnessing the boundary effect.

Proximity – Place the subwoofer as close as possible to the primary listening position. Sound dissipates indoors at approximately 4dB to 6dB for each time you double the distance from the subwoofer to the listener. Therefore you can expect a 4dB to 6dB increase in output every time you halve the distance from the subwoofer to the listener.

Improving the Stereo Image

Place the subwoofer(s) as close as possible to the satellite speakers.

Installation Fundamentals

Introduction

If you have doubts about whether you are capable of installing an in-wall speaker, consult a Niles dealer or professional installer. They have special tools, techniques, and experience to make the impossible possible. The installer can provide you with an estimate before any work is done.

Running the Speaker Wire in New Construction

Plan to schedule the speaker wiring after the electrical wiring is finished. That way you can avoid wire routes which could potentially induce hum over the speaker wire. The basic rules are:

- Never run speaker wire through the same hole as an electrical cable.
- Never run speaker wire into the same J-box as electrical cable.
- Avoid running the speaker wire beside the electrical cable. Keep it at least three or four feet away from any electrical power cable.

Side-by-side wiring is unavoidable in particular spots in every house, just move the speaker wire route away as soon as possible.

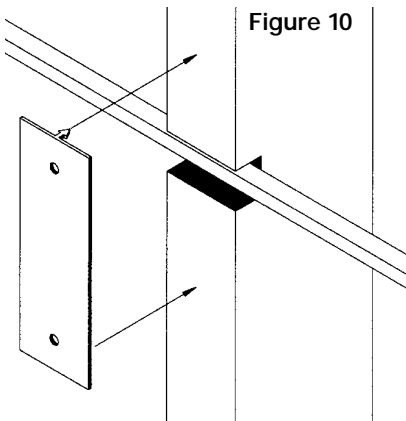

Figure 10

If construction forces a side by side run for more than ten feet, install metal conduit or shielded speaker wire. Low-voltage wires such as doorbells, intercoms, telephone, security, or television cannot cause interference or hum on your speaker wires, so you can safely run all of them at the same time, through the same holes, side-by-side.

Before you drill any holes, mount p-rings or open backed J-boxes where the volume controls and stereo equipment will be. If you are using the optional 800 New Construction Bracket kit-(FG00321) attach the wings and install them as instructed on pg.14, Installation in New Construction. (See Figure 15 and 16).

Safety First!

Wear gloves, safety goggles and head protection when drilling. Avoid nails, they ruin bits and they can cause injury.

Drilling

Use a bit that is large enough for the wires you plan to run. An auger bit is the preferred bit for rough-in wiring. It will actually pull itself through the wood, so that the drill motor, not you, does most of the work. You will be drilling a lot of holes, so this is important.

Always drill the holes in the center of the stud. If you have to notch the stud or drill the hole closer than one inch from the edge of the stud, protect the wire with a nail plate (See Figure 10).

When drilling holes in ceiling joists drill in the center of the joists and try to locate the hole near the end of the joist. DO NOT drill through a "gluelam" or any load bearing beam without the direction of your contractor.

Try to line the holes up perfectly, because it makes pulling the wire much easier.

A good technique is to snap a chalk line across the face of the studs or against the bottom of the ceiling joists. Then work backward so that you can always see the holes you have already drilled. Paying careful attention to this will save you a lot of time later on!

Pulling the Cable

Pull the cable in sections (from the stereo to the volume control, from the volume control to the speaker). Start with the longest sections and use left over wire to complete the short sections. If you plan to pull many rooms at the same time through a central route, walk off the distance to each destination, add a generous fudge factor for turns and other obstacles, then cut off each section so that you have a bundle of wires you can pull at once.

Whenever you run the wire further than four and one half feet from a hole in a stud or joist (open attic space, going up walls, etc.), fasten the wire to the joists or studs using cable clamps or appropriately sized wire staples. The wire should not have large sags in it, nor should it be too tight. Try to protect the wire from being stepped on in attics or other unfinished crawl spaces. There are guard strips, raceways and conduits which can be used to protect the cable. Consult the local building code for special requirements in your area.

Concealing Speaker Wire in Existing Walls

This is actually a fairly simple task if you restrict your choice of speaker locations and wire routes to the ceilings or interior walls of your home. Interior walls in almost all North American residences are hollow, so it is easy to flush mount speakers into them and route new speaker cable around the house. What you see when you look at the painted wall board, plaster, or paneling is only the skin of the wall. Behind the skin

is the skeleton; two-by-four wood or metal “studs” running vertically from the floor to the ceiling in walls and two-by-six or larger “joists” running horizontally in the ceilings and floors. In between the studs and the joists is the space for the wiring and plumbing of your home.

Exterior walls are different. They must insulate the house from the heat and cold outside, so they are stuffed with insulation. The national building code requires that the hollow wall space in exterior walls be broken by a horizontal stud placed between the vertical studs. This “fire blocking” makes it very difficult to retrofit long lengths of wire. In some areas of the country the exterior walls are constructed of solid masonry, and have no hollow space for speaker wires.

Start by examining all the possible routes you might take to run the speaker wire from the speaker to the volume control and back to the stereo. Use a stud sensor or other device to locate the internal structure of the wall. You want to avoid all studs or joists. A typical route would be: from the speaker location up the inside of the wall to a new hole drilled into the top “plate” (horizontal two-by-four at the top of the inside of the wall), into the attic crawl space, then down to the volume control location through another top plate, back up to the attic, across the attic, and finally down another plate to the wall behind the stereo system itself (**See Figure 11**). The other very common route is through the bottom plate of the wall into an unfinished basement or crawl space.

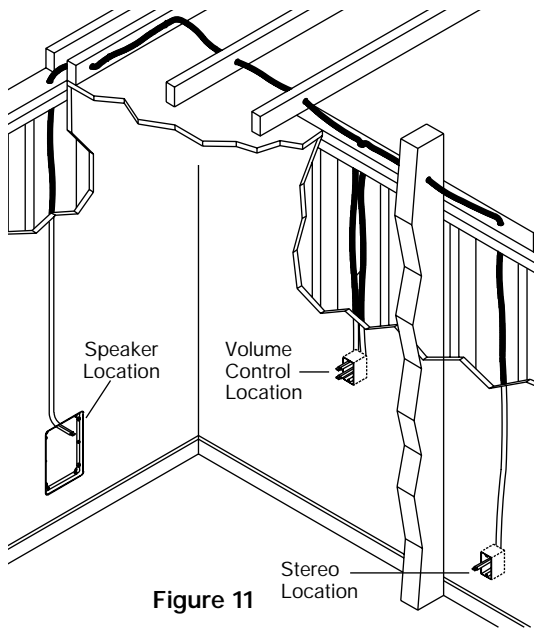

Figure 11

cover plate and switch or receptacle, and shining a penlight into the wall. If you have access to an attic or basement space you can quickly see which part of the wall space the wire is free of obstructions (See Figure 12).

When you don't have access above or below the wall, try to estimate the existing wire and pipe locations from the positions of electrical outlets and plumbed fixtures on both sides of the wall. Take a look at the outside of your house too, sometimes conduit, vents or drain pipe will be visible that give useful information. Choose the route with the fewest potential obstacles.

Identify where all of your electrical, phone, and TV wiring is likely to be and plan to route around it all. You can accidentally induce 60 Hz hum on your speakers if you run your speaker wire right beside electrical wire for more than a few feet. Try to keep speaker wire running parallel to power cables at least 3 feet away. To find exactly where an electrical cable is routed, try inspecting the inside of the wall by turning off the breaker for a particular power outlet or switch, removing the

If your house is built on a slab or you are wiring between two finished floors, look for baseboards which could be removed and replaced with the wire behind them. Doorjamb can be removed and often have enough space for speaker wire all the way around the door (See Figure 13).

Sometimes, an under-the-carpet run is possible (there are special flat speaker wires made for under-the-rug wire runs). As a last resort, heating and air conditioning vents can be used as wire raceways for

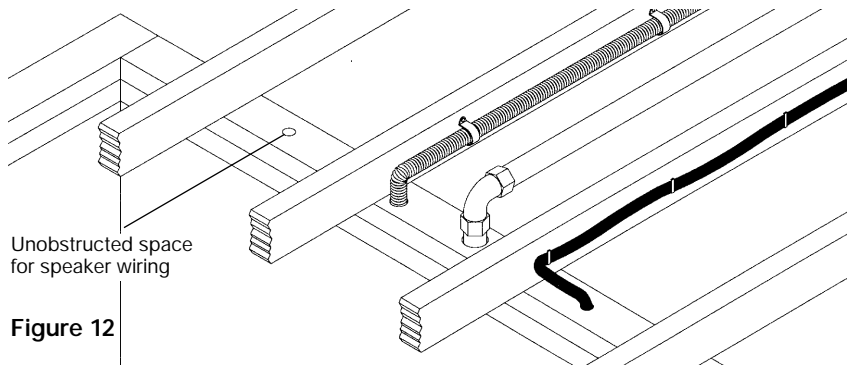

Unobstructed space for speaker wiring

Figure 12

plenum rated wire (check your local building codes, some municipalities require conduit).

In traditional wood stud/drywall construction you can cut the hole for the speaker and utilize the large hole to auger holes across, up or down the wall for as far as your drill bit will take you. If you have matching paint and take reasonable care in patching you can cut a hatch in the drywall at each stud, run your wire, and patch and touch-up the wall (See Figure 14).

When you are dealing with the unknown because of the structure of your home, or with difficult to patch wall materials like plaster, lath and plaster, faux finishes, wallpaper etc., be patient. A careful study of the potential problems before you start the job will pay off.

Figure 13

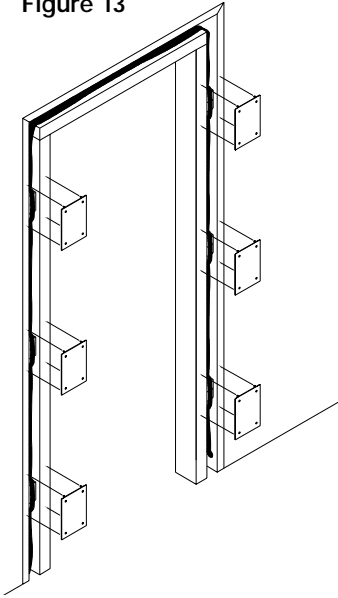
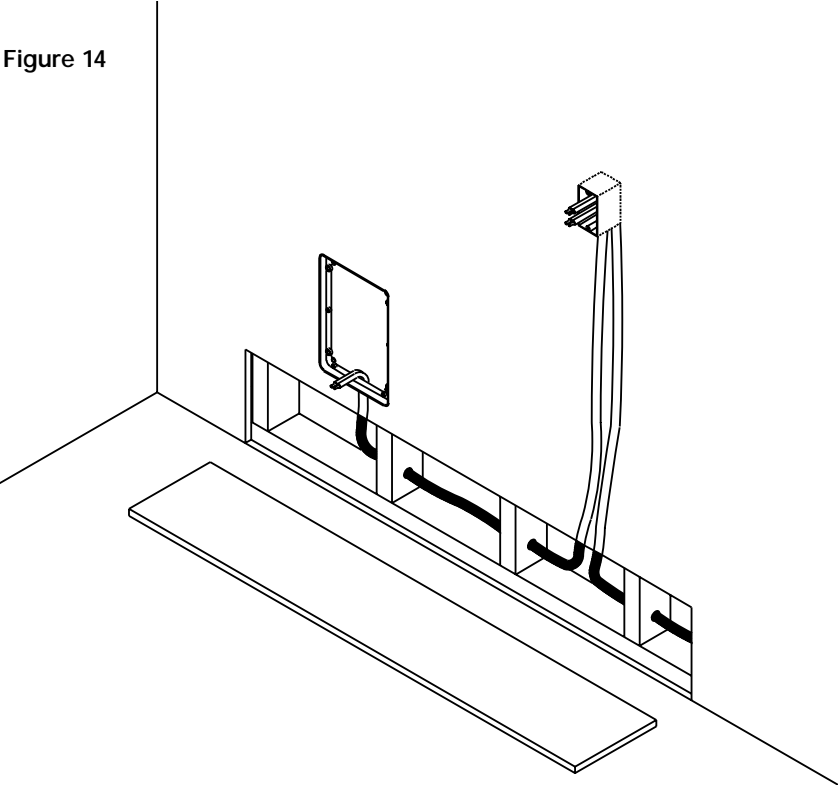

Figure 14



Installation in New Construction

Stage One: Before Drywall is Hung Insulating the Wall Cavity.

If feasible, fill the wall cavity with insulation at this point.

Mounting The Model 800 New Construction Bracket

The hole saving bracket enables a faster and cleaner final installation of the speaker. It forces the drywall installer to cut out the speaker hole for you and provides wire ties for the speaker wire, reducing the risks of accidental loss or movement of the wire. In addition, it enables you to align your speakers with other ceiling fixtures with great accuracy since you can really see exactly where the speaker will be.

To install the bracket, first attach the QuickSnap™ new construction wings to the bracket by snapping them into the sides of the bracket. The wings can be shortened by breaking them along the scored lines if their length will interfere with a corner or eaves. The wings and brackets have centering lines to simplify the placement of the speaker.

Screw one side of the assembled bracket with wings to the joist using one of the supplied screws. Level the bracket. Screw the other side of the bracket/wing assembly to the joist. Two screws on each side makes for a very secure installation. Secure the wire to the bracket using the bracket's wire tie (See Figure 15). The drywall installers will cut the drywall to the exact size of the bracket.

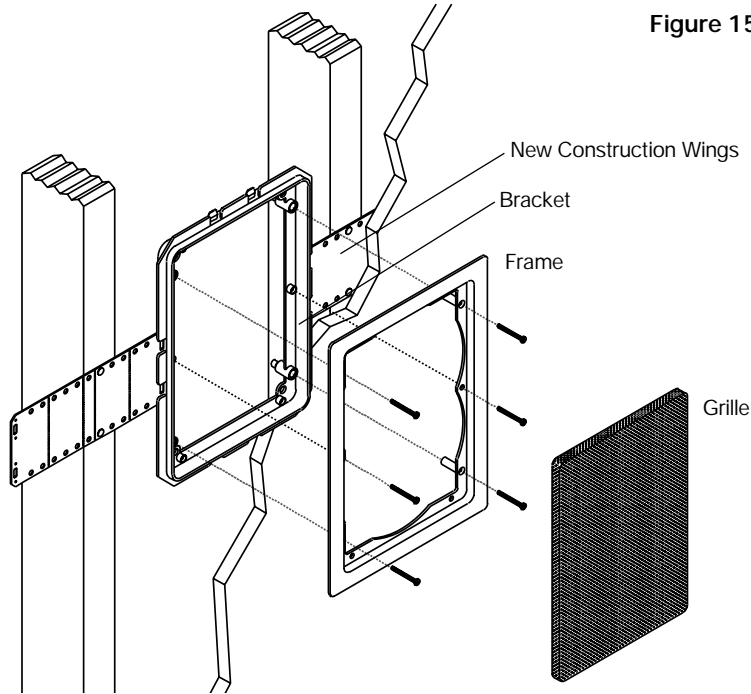

Figure 15

Installation of Brackets, Frames and Grilles in Existing Walls

IMPORTANT: Before you cut into any wall, review the sections on running wire and speaker placement.

1. Drill a 1/8" pilot hole just barely through the wallboard or dry wall (1/2" to 5/8" deep in most homes) about an inch below the center of your proposed speaker location (an inch to the side if you are mounting the speaker horizontally). **BE VERY CAREFUL NOT TO DRILL THROUGH EXISTING WIRES, PIPES, OR STRUCTURE. IF YOU FEEL ANY EXTRA RESISTANCE AS YOU ARE DRILLING, STOP.** Cut a piece of coat hanger equal to the width of the bracket. Bend the wire in half creating a right angle. Poke the "L-shaped" wire into the pilot hole and turn it

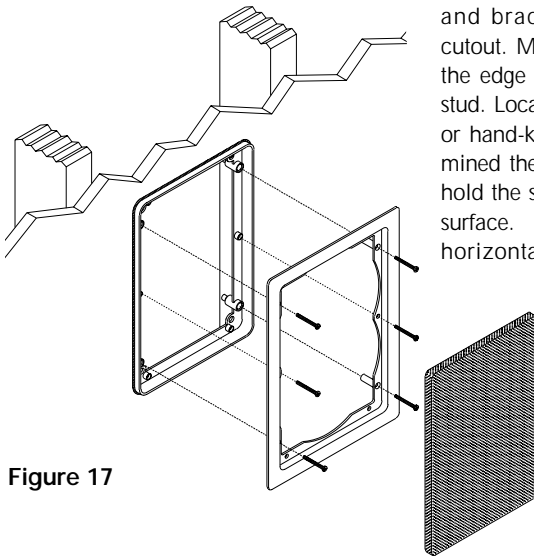

Figure 17

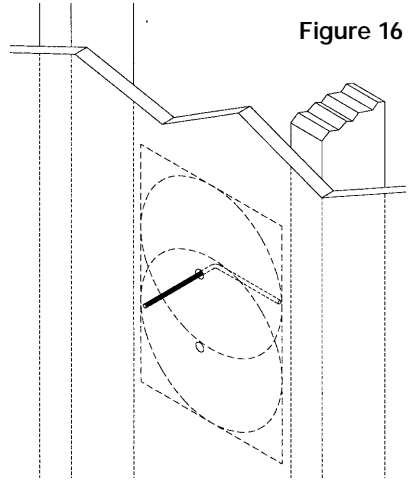

Figure 16

in a complete circle. If it turns freely, repeat the procedure from a hole about an inch above the center of your proposed speaker location (**See Figure 16**).

If the wires movement is obstructed by a pipe or cable, fill the hole (s) with spackle or other patching compound and try another location.

2. When determining the final location of the cutout keep in mind that the frame and bracket will extend beyond the cutout. Make sure that you do not place the edge of the cutout directly next to a stud. Locate the studs using a stud sensor or hand-knocking. Once you have determined the correct position for the cutout, hold the supplied template up to the wall surface. Level the template in either the horizontal or the vertical position and mark the wall with a pencil. Drill the four corners with a 1/4" drill bit.

3. If you are cutting a painted or wall papered drywall use a sheetrock or keyhole saw. Cut the hole with the saw at a 45 degree angle. That way,

the drywall section can be replaced cleanly if there is an unseen obstruction behind the wall. **BE VERY CAREFUL NOT TO SAW THROUGH EXISTING WIRES, PIPES, OR STRUCTURE. IF YOU FEEL ANY EXTRA RESISTANCE AS YOU ARE CUTTING, STOP.**

4. If you are cutting into lath and plaster walls, use masking tape to outline your penciled marks, drill the four corners with a 1/4" bit and use a razor to score the

plaster down to the lath beneath. Then use a chisel to remove all of the plaster within the taped outline. Finally, insert a metal cutting blade into a sabre saw and very slowly and carefully saw the lath. Sawing the lath can easily vibrate plaster off the wall. If you have the patience, use a pair of tin snips to slowly nip away at the lath instead. There is no risk with this method, it is just time consuming.

Final Installation in New or Existing Construction

1. If it is possible to lay a batt of insulation into the wall cavity, do so. Remember to use equal amounts of insulation for each speaker. Install any other wall cavity improvements or modifications at this time.

2. Separate the speaker wire so that at least two inches of each conductor are free.

3. Strip one half inch of insulation from the end of each conductor of the speaker wire.

4. If you have gold pin connectors which you wish to use, affix them to the stripped wire ends now.

5. Connect one stripped wire end of the wire connected to the amplifiers right channel output to the black and one to the red input terminals labeled for the right channel. Pay attention to the markings on the wire. Repeat for the left channel.

6. Connect the wire which runs to the satellite speakers to the left and right output terminals. Pay attention to the markings on the wire.

7. Slip the mounting bracket through the hole and pull it toward you so that its front edge slides into the hole and stops in place.

8. Attach the frame to the bracket by screwing the frame to the bracket using the supplied screws. Do not overtighten the screws, this will distort the frame and the grilles will not fit (this is not permanent, just loosen the screws and the grille will pop in). The screws should pull the frame and bracket together (sandwiching the drywall) so that the frame is absolutely flush with the wall surface. There should be no gaps between the wall and the frame (**See Figure 17**).

9. Installing a Niles MS-1 MicroSensor™
There is a 1/2" round molded "IR Sensor Knockout" on the face of the speaker baffle. To prevent damage to the crossover network you must remove the knockout from the rear of the speaker. Do not attempt to remove the knockout with the speaker face up. Lay the speaker face down on a clean carpet or rug. Put the tip of a screwdriver into the center of the round "knockout" and sharply tap the screwdriver handle as necessary. Install the MS-1 using its mounting hex nut and washer so that it is tightly secured to the speaker. Connect all wires and continue your installation.

10. Setting the High-Pass Filter

When the "SAT" filter is in the CUT position, all of the bass energy will be produced via the PSW800. When the switch is in the FULL position, both the satellite speakers and the PSW800 will reproduce the bass signal. Typically, satellites with woofers that are 5-1/4" or smaller will sound best with the filter on. Listen to a loud and well recorded bass passage to evaluate.

11. Setting the Subwoofer Low-Pass Filter

With the "SUB" switch in the 100Hz position, the PSW800 will only reproduce bass below one hundred cycles. When the switch is in the 140Hz position, the PSW800 will reproduce bass below 140 cycles. Depending on the size of the room, the type of satellite speaker and the subwoofer position, you will prefer one setting to the other. Listen to a loud and well recorded bass passage to evaluate.

12. Install the grille into the speaker. The grilles should fit snugly. If you have difficulty fitting them in, try loosening the screws used to secure the frame to the bracket slightly (excessive tightening can distort the shape of the frame holding the grille in place).

Painting the Speakers

All models may be painted. The plastic will readily accept most paints.

The subwoofers must be masked prior to painting them. The inside rectangular portion of the hole template can be used as a paint mask. Remove the outside portion of the template by gently pulling along the perforation. Affix the mask to the front of the speaker by friction-fitting the mask into the bezel.

The grilles should be painted before they are installed. For all models, the best results will be obtained by using a spray

gun or airless sprayer, thinning the paint (prevents clogging of grille holes), and by applying several light coats instead of one heavy one.

Speaker/Subwoofer Phase

Speaker wire has two conductors. One conductor is attached to the negative (-) terminals and one conductor is attached to the positive (+) terminals of both your speaker and your amplifier. Usually, the wire is marked for your convenience. There are different ways wires are marked: a stripe on one wire, a ribbed area of one conductor you can only feel, different colors of metal wire on each conductor, or there might be a fabric strand or string wound into one of the conductors. Of course, there are some wires which appear completely identical. Be careful, or you might make a mistake.

If you make a mistake, there are three possibilities:

1) Subwoofer Input Phase Reversal

The Left Input of the subwoofer is out of phase with the Right Input. If this is the case, you will hear almost no output out of the subwoofer when playing a loud bass passage. Try reversing one of the subwoofer inputs. If the sound gets a great deal louder, that was the problem. If bass sound was reduced, return the connections to their original state.

2) Subwoofer /Satellite Relative Phasing

An acoustically out-of-phase sat/sub combination works against each other and the sound of the overall system will be lacking in bass. This might be because of the *position of the subwoofer* rather than an error in wiring. Try reversing the phase of both the left and the right outputs of the subwoofer. Make sure you evaluate (listen) from the primary listening position.

3) Satellite Left-Right Phase Reversal

If the right satellite is reversed in phase from the connections on the left satellite, you will hear reduced bass and a “phasey” diffused vocal image. If you suspect the sound is not right and you cannot see any markings on the wire, try this simple test:

1. Stand half way between the two satellite speakers.
2. Play some vocal music with the amplifier or radio set to Mono.

3. Listen to the apparent placement of the vocals.
4. Turn off the amplifier and reverse one of the connections on the subwoofer.
5. Repeat the listening test with the same setting of the volume control. When the sound has a richer bass, is slightly louder and the vocal image is “focused” the satellites are working together or “in-phase”.

Operation

Congratulations

A concealed PSW800 subwoofer installation frees you to use your tone controls, play the system loudly and enjoy deep extended bass, even if your satellite speakers are small. When used with satellite speakers that have substantial bass of their own, the PSW800 tightens the deep tones and augments the bass musically.

Listening at Higher Volumes

It requires more power to achieve a reasonable volume of sound in a large room than it does in a small room. It is possible (even if you are not a teenager) to turn the volume so high that the amplifier *runs out of power*. This creates “clipping” distortion. If you are using an extremely powerful amplifier it may be possible to hear clicking or buzzing sounds from the subwoofer as it tries to reproduce too loud a sound. If you hear these sounds turn the volume down. More typically you will hear clipping distortion through your satellite speakers. Clipping distortion makes treble sound very harsh and unmusical. When you hear harsh sounding treble from any good speaker,

turn the volume down immediately! Those harsh sounds are masking some much more powerful ultra-high-frequency sound spikes which will quickly damage any fine loudspeaker. You are much less likely to damage a speaker with a large amplifier because it will be very loud indeed before it produces any clipping distortion.

Cleaning

You can clean the speaker with a dampened soft cloth or paper towel. If the speaker is mounted high up on the wall, use a broom to gently brush it off.

Specifications

Model PSW800

Driver Complement

8" Mica-filled polypropylene dual voice coil woofer with inverted butyl-rubber suspension and dust cap

Design Principle

Infinite baffle for large and varying air volumes

Recommended Amplifier Power

Ten to one hundred fifty watts per channel

Impedance

8 Ohm - Single Subwoofer in Stereo

4 Ohm - Single Subwoofer with Voice Coils

Paralleled for full monophonic output

Frequency Response

35 Hz to 140 Hz, plus or minus 3dB
(on axis)

Sensitivity

89 decibels for 2.83 volts of pink noise,
measured at 1 meter on axis

Overall Exterior Frame Dimensions

10-3/16" x 14-1/4"

Depth Behind Wall

3-3/4" (assumes 1/2" drywall)

Wall Cut-Out Dimensions

9-1/8" x 13-1/8"

Connections

Left and right channel input and outputs via spring loaded push terminals. Accommodates up to 14 gauge wire.

PLEASE FILL OUT THE
WARRANTY REGISTRATION
CARD ON THE REVERSE SIDE,
DETACH, AND MAIL TO:

Niles Audio Corporation
Warranty Registration Dept.
P.O. Box 160818
Miami, Florida 33116-0818

DETACH HERE



WARRANTY REGISTRATION CARD

Model Purchased _____

Serial Number _____

Date Purchased (month/day/year) _____

Dealer Name and Location _____

Dr. Miss Mr. Mrs. Ms.

Name _____

Address _____

City _____ State _____ Zip _____

Telephone (_____) _____

Please take a moment to fill out our warranty registration card. The information helps us to get to know you better and develop the products you want

Age:

- Under 25
- 25-34
- 35-44
- 45-54
- 55 & over

Income:

- Under \$24,999
- \$25,000-\$34,999
- \$35,000-\$44,999
- \$45,000-\$59,999
- \$60,000-\$74,999
- \$75,000-\$99,999
- Over \$99,999

Occupation:

- Arts/Entertainment
- Business Owner
- Engineer
- Finance/Accounting
- General Office
- Management
- Professional
- Sales/Marketing
- Student
- Tradesperson

Musical tastes:

(Please check all that apply)

- Alternative
- Classical
- Country
- Jazz
- New Age
- Popular
- R&B
- Rock
- Other _____

How did you hear about Niles?

- Architect/Developer
- Custom Installer
- Direct Mail
- Friend/Family
- In-Store Display
- Interior Designer
- Magazine Ad
- Mail-Order Catalog
- Newspaper Ad
- Product Brochure
- Product Review
- Retail Salesperson

What magazines do you read?

1. _____
2. _____
3. _____

Who will install the product?

- Custom Installer
- Electrician
- Friend
- Myself

Which factor(s) influenced the purchase of your Niles product?

(Please check all that apply)

- Ease of Use
- Price/Value
- Product Features
- Quality/Durability
- Reputation
- Style/Appearance
- Warranty

Do you . . . ?

- Own a House. If yes, how many square feet? _____
- Own a Town House/Condominium/Co-op
- Rent an Apartment
- Rent a House

Are you interested in receiving literature on other Niles products?

- Yes No

Are there products/capabilities that you would like to see introduced?

Limited Warranty

Niles Audio Corporation ("NILES") warrants its loudspeaker products to the original purchaser to be free of manufacturing defects in material and workmanship for a period of five years from date of purchase.

This Warranty is subject to the following additional conditions and limitations. The Warranty is void and inapplicable if NILES deems that the product has been used or handled other than in accordance with the instructions provided by the manufacturer, including but not limited to damage caused by accident, mishandling, improper installation, abuse, negligence, or normal wear and tear, or any defect caused by repair to the product by anyone other than NILES or an authorized NILES dealer.

To obtain warranty service, take the unit to the nearest authorized NILES dealer, who will test the product and if necessary, forward it to NILES for service. If there are no authorized NILES dealers in your area, you must write to NILES and include your name, address, model and serial number of your unit, along with a brief description of the problem. A factory Return Authorization Number will be sent to you. **DO NOT RETURN ANY UNIT WITHOUT FIRST RECEIVING WRITTEN AUTHORIZATION AND SHIPPING INSTRUCTIONS FROM NILES.**

If the above conditions are met, the purchaser's sole remedy shall be to return the product to NILES, in which case NILES will repair or replace, at its sole option, the defective product without charge for parts or labor. NILES will return a unit repaired or replaced under warranty by shipping same by its usual shipping method from the factory (only) at its expense within the United States of America. **THERE ARE NO OTHER WARRANTIES, INCLUDING WITHOUT LIMITATION, EITHER EXPRESS OR IMPLIED WARRANTIES OF MERCHANTABILITY OR FITNESS FOR A PARTICULAR PURPOSE, WITH RESPECT TO THE PRODUCT.**

REPAIR OR REPLACEMENT AS PROVIDED UNDER THIS WARRANTY IS THE EXCLUSIVE REMEDY OF THE CONSUMER/PURCHASER. NILES SHALL NOT BE RESPONSIBLE FOR ANY INCIDENTAL OR CONSEQUENTIAL DAMAGES EXCEPT TO THE EXTENT PROVIDED (OR PROHIBITED) BY APPLICABLE LAW.

Some states do not allow the exclusion or limitation of incidental or consequential damages, so the above limitation may not apply to you. This warranty gives you specific legal rights, and you may also have other rights which vary from state to state.

For the name of your nearest authorized NILES dealer contact:

NILES AUDIO CORPORATION
P.O. BOX 160818, Miami, Florida 33116-0818.

Please fill in your product information and retain for your records.

Model _____

Serial No. _____

Purchase Date _____



NILES®

www.nilesaudio.com

Niles Audio
Corporation

12331 S.W. 130 Street
Miami, Florida 33186
Tel: (305) 238-4373
Fax: (305) 238-0185

Printed in Taiwan

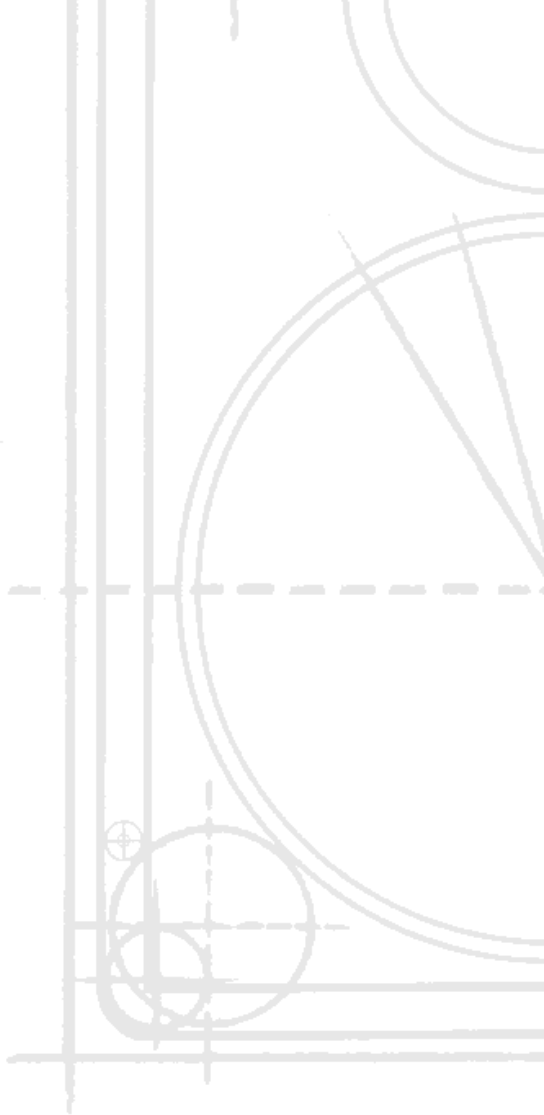

blue
ser

© 1999 Niles Audio Corporation. DS00206A

N - W
LOUDSP